

APPARECCHI A MASCHIARE	Art. MAR	CM ...
TAPPING INSTRUMENTS	Art. MAR	CM ...
EQUIPAMENTO A ROSCAR A MACHO	Art. MAR	CM ...

MASCHIATORI ATTACCO RAPIDO PER MASCHIARE CON COMPENSAZIONE ASSIALE
QUICK CHANGE TAPPING WITH AXIAL COMPENSATION
ROSCADORES RÁPIDA PARA ROSCAR A MACHO CON COMPENSAZIÓN AXIAL

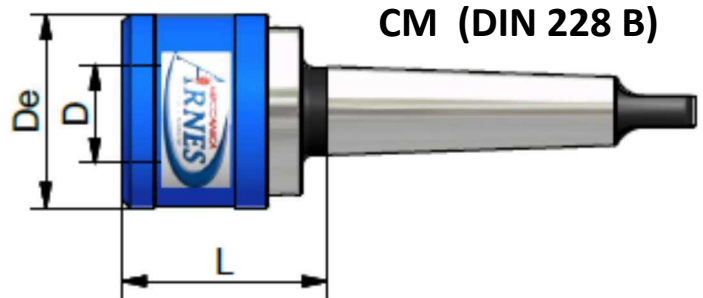

ART	Campo di filettatura For Taps	Per Bussole Suitable for adaptor size	Compensazione assiale Length Compensation		DE ∅	D ∅	CM 2 L	CM 3 L	CM 4 L
			Press. Comp.	Traz. Exp.					
MAR 1 CM 2	M 3 – M 12	1	7,5	7,5	36	19	47	-	-
MAR 1 CM 3	M 3 – M 12	1	7,5	7,5	36	19	-	47	-
MAR 2 CM 3	M 8 – M 20	2	12,5	12,5	53	31	-	71	-
MAR 2 CM 4	M 8 – M 20	2	12,5	12,5	53	31	-	-	72
MAR 3 CM 4	M14 – M33	3	20	20	78	48	-	-	105

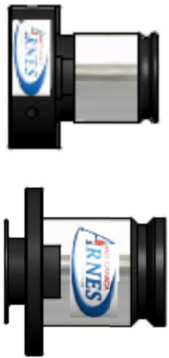
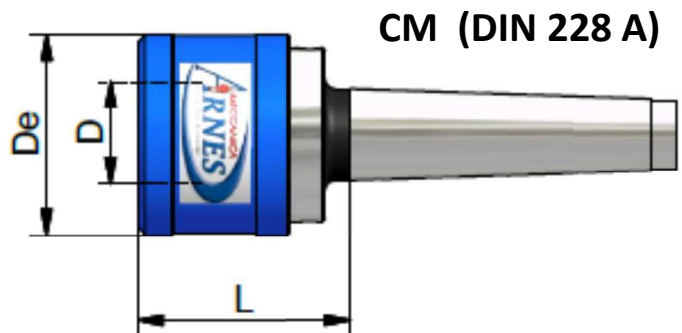
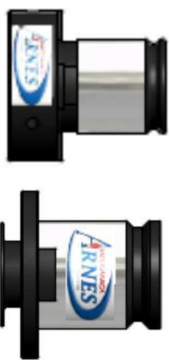

ART	Campo di filettatura For Taps	Per Bussole Suitable for adaptor size	Compensazione assiale Length Compensation		DE ∅	D ∅	CM 2 L	CM 3 L	CM 4 L
			Press. Comp.	Traz. Exp.					
MAR 1 CM 2	M 3 – M 12	1	7,5	7,5	36	19	47	-	-
MAR 1 CM 3	M 3 – M 12	1	7,5	7,5	36	19	-	47	-
MAR 2 CM 3	M 8 – M 20	2	12,5	12,5	53	31	-	71	-
MAR 2 CM 4	M 8 – M 20	2	12,5	12,5	53	31	-	-	72
MAR 3 CM 4	M 14 – M 33	3	20	20	78	48	-	-	105

APPARECCHI A MASCHIARE	Art. MAR	Cil ...
TAPPING INSTRUMENTS	Art. MAR	Cil ...
EQUIPAMENTO A ROSCAR A MACHO	Art. MAR	Cil ...

MASCHIATORI ATTACCO RAPIDO PER MASCHIARE CON COMPENSAZIONE ASSIALE
QUICK CHANGE TAPPING WITH AXIAL COMPENSATION
ROSCADORES RÁPIDA PARA ROSCAR A MACHO CON COMPENSAZIÓN AXIAL

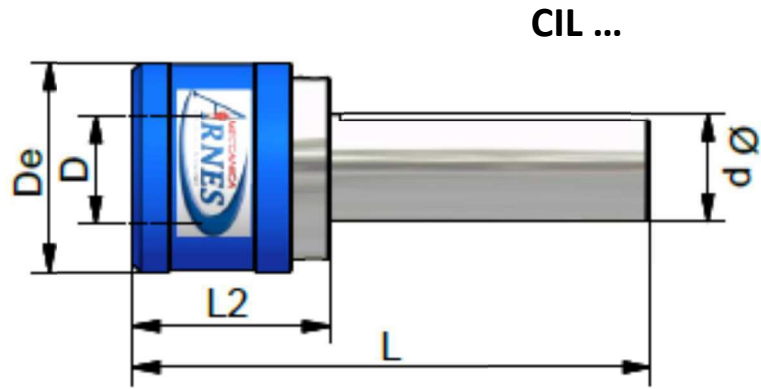
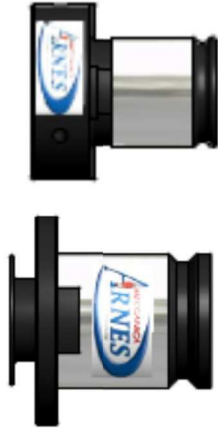

ART	Campo di filettatura For Taps	Per Bussole Suitable for adaptor size	Compensazione assiale Length Compensation		De Ø	D Ø	L	L2	L1	d Ø
			Press. Comp.	Traz. Exp.						
MAR 1 C 16	M 3 – M 12	1	7,5	7,5	36	19	80	40	40	16
MAR 1 C 20	M 3 – M 12	1	7,5	7,5	36	19	80	40	40	20
MAR 1 C 25	M 3 – M 12	1	7,5	7,5	36	19	100	40	60	25
MAR 1 C 32	M 3 – M 12	1	7,5	7,5	36	19	100	40	60	32
MAR 2 C 25	M 8 – M 20	2	12,5	12,5	53	31	124	40	60	25
MAR 2 C 32	M 8 – M 20	2	12,5	12,5	53	31	124	64	60	32

NOTE:

APPARECCHI A MASCHIARE	Art. MAR V ...
TAPPING INSTRUMENTS	Art. MAR V ...
EQUIPAMENTO A ROSCAR A MACHO	Art. MAR V ...

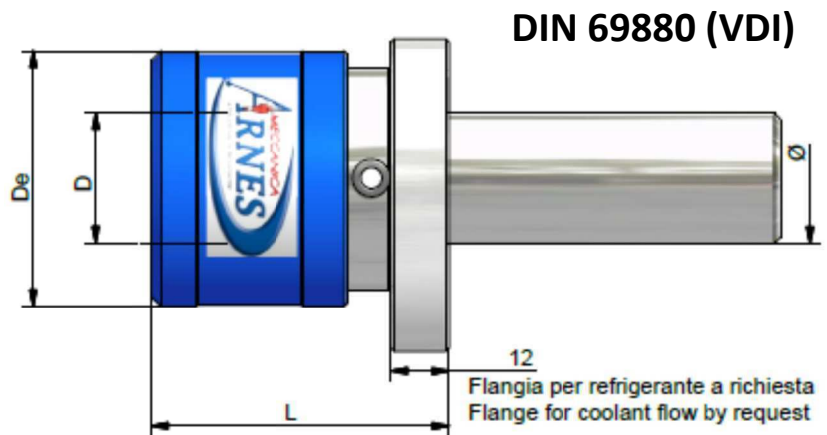
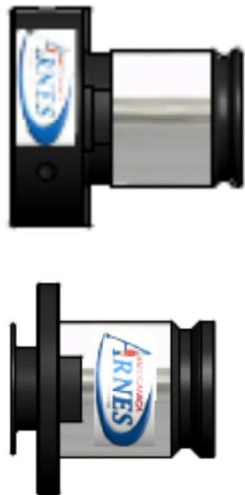

ART	Campo di filettatura For Taps	Per Bussole Suitable for adaptor size	Compensazione assiale Length Compensation		De ∅	D ∅	L	∅
			Press. Comp.	Traz. Exp.				
MAR 1 V 20	M 3 – M 12	1	7,5	7,5	36	19	53	20
MAR 1 V 30	M 3 – M 12	1	7,5	7,5	36	19	56	30
MAR 1 V 40	M 3 – M 12	1	7,5	7,5	36	19	56	40
MAR 1 V 50	M 3 – M 12	1	7,5	7,5	36	19	56	50
MAR 2 V 30	M 8 – M 20	2	12,5	12,5	53	31	77	30
MAR 2 V 40	M 8 – M 20	2	12,5	12,5	53	31	77	40
MAR 2 V 50	M 8 – M 20	2	12,5	12,5	53	31	80	50

NOTE:

APPARECCHI A MASCHIARE	Art. MAR Tr ...
TAPPING INSTRUMENTS	Art. MAR Tr ...
EQUIPAMENTO A ROSCAR A MACHO	Art. MAR Tr ...

MASCHIATORI ATTACCO RAPIDO PER MASCHIARE CON COMPENSAZIONE ASSIALE
QUICK CHANGE TAPPING WITH AXIAL COMPENSATION
ROSCADORES RÁPIDA PARA ROSCAR A MACHO CON COMPENSAZIÓN AXIAL

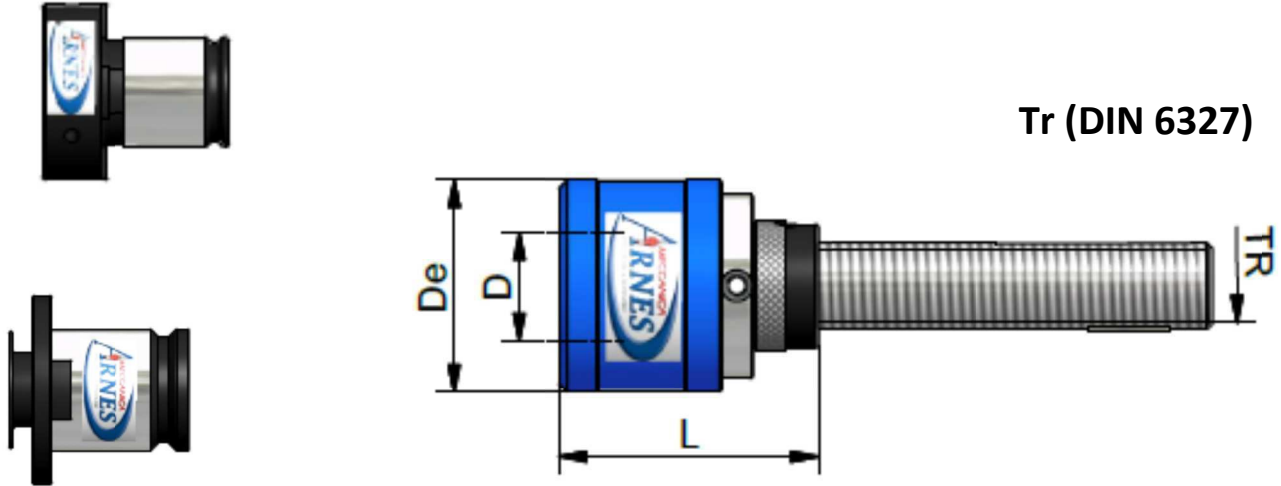

ART	Campo di filettatura For Taps	Per Bussole Suitable for adaptor size	Compensazione assiale Length Compensation		De Ø	D Ø	L	TR
			Press. Comp.	Traz. Exp.				
MAR 0T 16x1,5	M 1 – M 10	0	6,5	6,5	26	13	50	16x1,5
MAR 0T 20x2	M 1 – M 10	0	6,5	6,5	26	13	50	20x2
MAR 1T 16x1,5	M 3 – M12	1	7,5	7,5	26	19	52	16x1,5
MAR 1T 20x2	M 3 – M12	1	7,5	7,5	26	19	52	20x2
MAR 1T 28x2	M 3 – M12	1	7,5	7,5	26	19	52	28x2
MAR 1T 36x2	M 3 – M12	1	7,5	7,5	26	19	54	36x2
MAR 2T 20x2	M 8 – M 20	2	12,5	12,5	53	31	76	20x2
MAR 2T 28x2	M 8 – M 20	2	12,5	12,5	53	31	76	28x2
MAR 2T 36x2	M 8 – M 20	2	12,5	12,5	53	31	78	36x2

APPARECCHI A MASCHIARE	Art. MAR B ...
TAPPING INSTRUMENTS	Art. MAR B ...
EQUIPAMENTO A ROSCAR A MACHO	Art. MAR B ...

MASCHIATORI ATTACCO RAPIDO
QUICK CHANGE TAPPING
ROSCADORES RÁPIDA

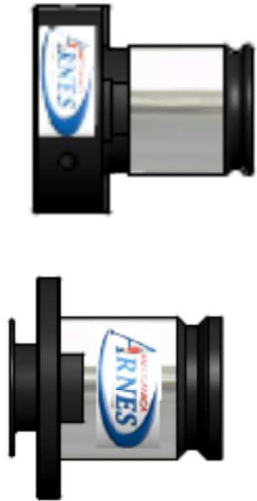

DIN 238

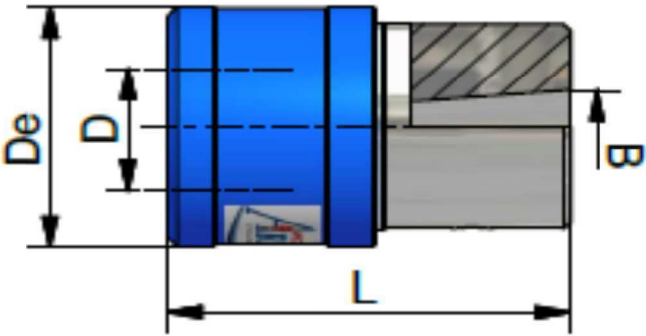

ART	Campo di filettatura For Taps	Per Bussole Suitable for adaptor size	De ∅	D ∅	L	B
MAR0 B10	M 1 – M 7	1	33	13	55	10
MAR0 B12	M 1 – M 7	1	33	13	55	12
MAR1 B10	M 3 – M 12	1	32	19	56	10
MAR1 B12	M 3 – M 12	1	32	19	56	12
MAR1 B16	M 3 – M 12	1	32	19	65	16
MAR2 B12	M 8 – M 20	2	50	31	76	12
MAR2 B16	M 8 – M20	2	50	31	86	16
MAR2 B18	M 8 – M 20	2	50	31	90	18

* Attacchi speciali a richiesta JACOBS, ecc. ...

* Special attachment by request

* Apéndice a pedido especial

NOTE:

APPARECCHI A MASCHIARE	Art. MAR
TAPPING INSTRUMENTS	Art. MAR
EQUIPAMENTO A ROSCAR A MACHO	Art. MAR

MASCHIATORI ATTACCO RAPIDO PER MASCHIARE CON COMPENSAZIONE ASSIALE
QUICK CHANGE TAPPING WITH AXIAL COMPENSATION
ROSCADORES RÁPIDA PARA ROSCAR A MACHO CON COMPENSAZIÓN AXIAL

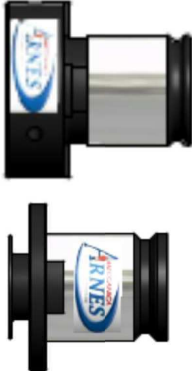

MAS 403 – BT

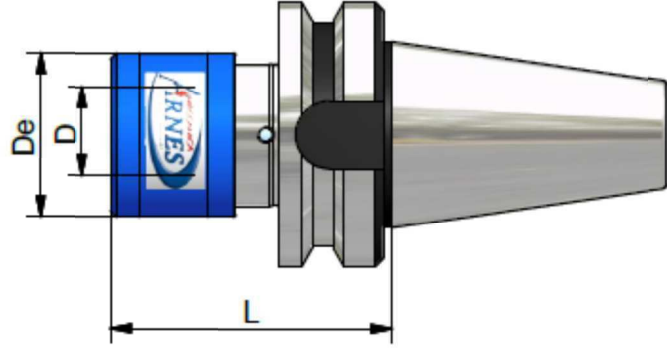

ART	Campo di filettatura For Taps	Per Bussole Suitable for adaptor size	Compensazione assiale Length Compensation		De Ø	D Ø	L
			Press. Comp.	Traz. Exp.			
MAR 1 – MAS 403 BT 30	M 3 – M 12	1	7,5	7,5	36	19	62,5
MAR 1 – MAS 403 BT 40	M 3 – M 12	1	7,5	7,5	36	19	67,5
MAR 2 – MAS 403 BT 40	M 8 – M 20	2	12,5	12,5	53	31	94,5
MAR 2 – MAS 403 BT 50	M 8 – M 20	2	12,5	12,5	53	31	102,5

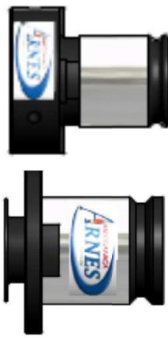

DIN 69871

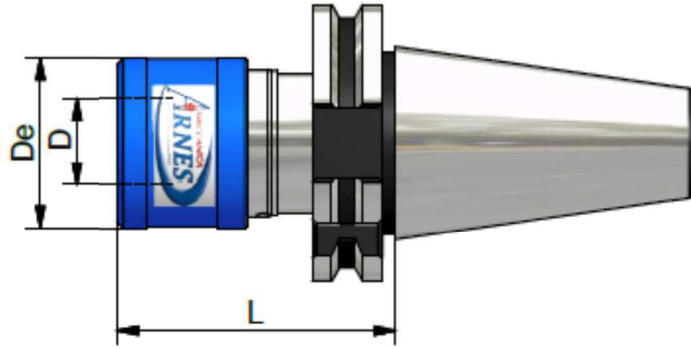

ART	Campo di filettatura For Taps	Per Bussole Suitable for adaptor size	Compensazione assiale Length Compensation		De Ø	D Ø	L
			Press. Comp.	Traz. Exp.			
MAR 1 – DIN 69871 ISO 30	M 3 – M 12	1	7,5	7,5	36	19	64
MAR 1 – DIN 69871 ISO 40	M 3 – M 12	1	7,5	7,5	36	19	60
MAR 1 – DIN 69871 ISO 50	M 3 – M 12	1	7,5	7,5	36	19	60
MAR 2 – DIN 69871 ISO 40	M 8 – M 20	2	12,5	12,5	53	31	98
MAR 2 – DIN 69871 ISO 50	M 8 – M 20	2	12,5	12,5	53	31	84

APPARECCHI A MASCHIARE	Art. MAR
TAPPING INSTRUMENTS	Art. MAR
EQUIPAMENTO A ROSCAR A MACHO	Art. MAR

MASCHIATORI ATTACCO RAPIDO PER MASCHIARE CON COMPENSAZIONE ASSIALE
QUICK CHANGE TAPPING WITH AXIAL COMPENSATION
ROSCADORES RÁPIDA PARA ROSCAR A MACHO CON COMPENSAZIÓN AXIAL

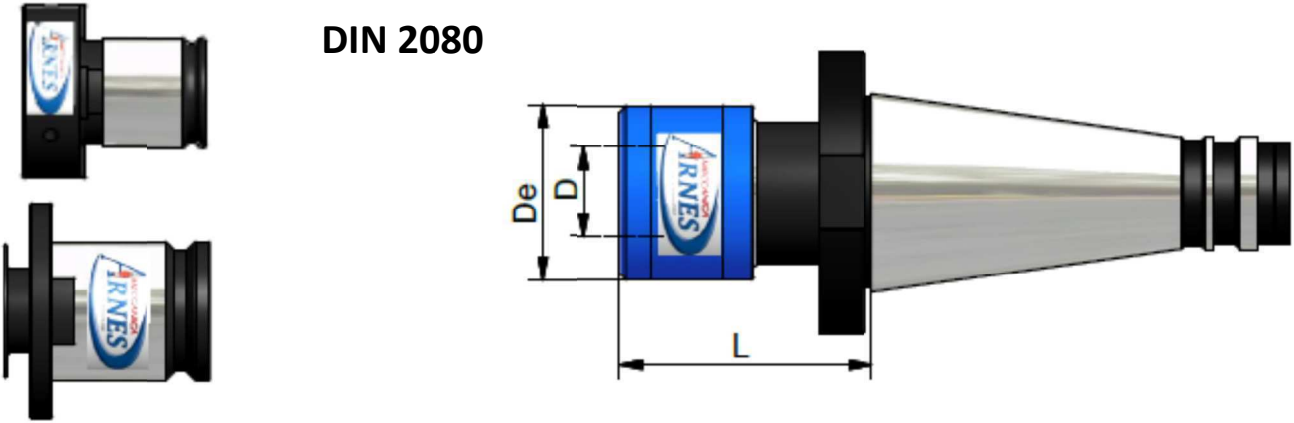

ART	Campo di filettatura For Taps	Per Bussole Suitable for adaptor size	Compensazione assiale Length Compensation		De ∅	D ∅	L
			Press. Comp.	Traz. Exp.			
MAR 1 – DIN 2080 ISO 30	M 3 – M 12	1	7,5	7,5	36	19	59
MAR 1 – DIN 2080 ISO 40	M 3 – M 12	1	7,5	7,5	36	19	50
MAR 1 – DIN 2080 ISO 50	M 3 – M 12	1	7,5	7,5	36	19	54
MAR 2 – DIN 2080 ISO 40	M 8 – M 20	2	12,5	12,5	53	31	78
MAR 2 – DIN 2080 ISO 50	M 8 – M 20	2	12,5	12,5	53	31	80

NOTE:

APPARECCHI A MASCHIARE	Art. MAR HSK ...
TAPPING INSTRUMENTS	Art. MAR HSK ...
EQUIPAMENTO A ROSCAR A MACHO	Art. MAR HSK ...

MAR 1 HSK ...

NEW

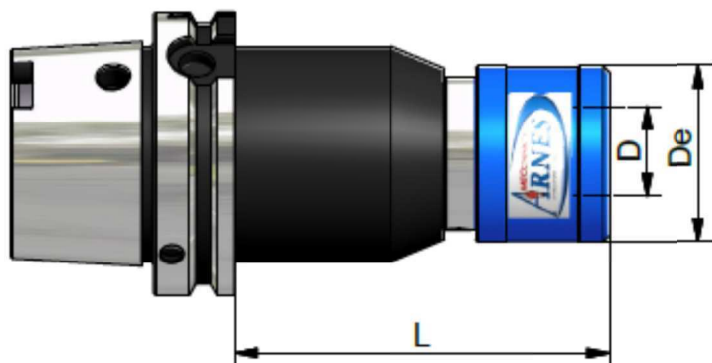

ART	Campo di filettatura For Taps	Per Bussole Suitable for adaptor size	Compensazione assiale Length Compensation		De ∅	D ∅	L
			Press. Comp.	Traz. Exp.			
MAR1HSK...40	M3 - M12	1	7,5	7,5	36	19	120
MAR1HSK...50	M3 - M12	1	7,5	7,5	36	19	120
MAR1HSK...63	M3 - M12	1	7,5	7,5	36	19	120
MAR1HSK...100	M3 - M12	1	7,5	7,5	36	19	120

NEW

MAR2 HSK...

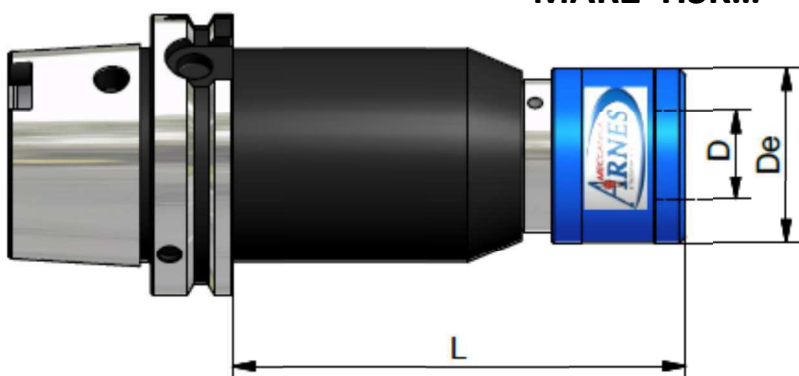

ART	Campo di filettatura For Taps	Per Bussole Suitable for adaptor size	Compensazione assiale Length Compensation		De ∅	D ∅	L
			Press. Comp.	Traz. Exp.			
MAR2HSK40	M8 - M20	2	12,5	12,5	53	31	170
MAR2HSK50	M8 - M20	2	12,5	12,5	53	31	170
MAR2HSK63	M8 - M20	2	12,5	12,5	53	31	170
MAR2HSK100	M8 - M20	2	12,5	12,5	53	31	170

**DIMENSIONE GAMBI MASCHI DIN
TAP SHANK DIMENSIONS TO DIN
TAMAÑO TALLO MACHO DIN**

Dimensione Ø x □ Dimension Ø x □	DIN 352	DIN 353	DIN 371	DIN 374	DIN 376	DIN 2182	DIN 2183
2,5 x 2,1	M 1	-	M 1	-	M 3,5	1/6"	-
	M 1,1	-	M 1,1	M 3,5	-	-	-
	M 1,2	-	M 1,2	-	-	-	-
	M 1,4	-	M 1,4	-	-	-	-
	M 1,6	-	M 1,6	-	-	-	-
	M 1,8	-	M 1,8	-	-	-	-
2,8 x 2,1	M 2	-	M 2	M 4	M 4	3/32"	5/32"
	M 2,2	-	M 2,2	-	-	-	-
	M 2,5	-	M 2,5	-	-	-	-
3,5 x 2,7	M 3	-	M 3	M 5	M 5	1/8"	-
4 x 3	M 3,5	-	M 3,5	-	-	-	-
4,5 x 3,4	M 4	-	M 4	M 6	M 6	5/32"	1/4"
6 x 4,9	M 5	-	M 5	-	-	7/32"	-
	M 6	-	M 6	-	-	-	-
	M 8	-	-	M 8	M 8	-	-
7 x 5,5	M 10	G 1/8"	-	M 10	M 10	1/4"	3/8"
8 x 6,2	-	-	M 8	-	-	5/16"	7/16"
9 x 7	M 12	-	-	M 12	M 12	3/8"	1/2"
10 x 8	-	-	M 10	-	-	-	-
11 x 9	M 14	G 1/4"	-	M 14	M 14	-	9/16"
12 x 9	M 16	G 3/8"	-	M 16	M 16	-	5/8"
14 x 11	M 18	-	-	M 18	M 18	-	11/16"
16 x 12	M 20	G 1/2"	-	M 20	M 20	-	13/16"
18 x 14,5	M 22	G 5/8"	-	M 22	M 22	-	7/8"
	M 24	-	-	M 24	M 24	-	15/16"
20 x 16	M 27	G 3/4"	-	M 27	M 27	-	1"
22 x 18	M 30	G 7/8"	-	M 30	M 30	-	1.1/8"
25 x 20	M 33	G 1"	-	M 33	M 33	-	1.1/4"
28 x 22	M 36	G 1.1/8"	-	M 36	M 36	-	1.3/8"
32 x 34	M 39	G 1.1/4"	-	M 39	M 39	-	1.1/2"
	M 42	-	-	M 42	M 42	-	1.5/8"
36 x 29	M 45	G 1.3/8"	-	M 45	M 45	-	1.3/4"
	M 48	G 1.1/2"	-	M 48	M 48	-	1.7/8"
	-	G 1.3/4"	-	-	-	-	-
	-	G 2"	-	-	-	-	-
40 x 32	M 52	G 2.1/4"	-	M 52	M 52	-	2"
45 x 35	M 56	G 2.1/2"	-	-	M 56	-	2.1/4"
	M 60	-	-	-	M 60	-	-
50 x 39	M 64	G 2.3/4"	-	-	M 64	-	2.1/2"
	-	G 3"	-	-	-	-	-
56 x 44	M 68	G 3.1/4"	-	-	M 68	-	2.3/4"
	-	-	-	-	-	-	3"

DIMENSIONE GAMBI MASCHI ISO
TAP SHANK DIMENSIONS TO ISO
TAMAÑO TALLO MACHO ISO

ISO 529 - 1975												
Dim. ∅ x □	M		UNC		UNF		BSW		BSF		BA	
		*		*		*		*		*		*
2,24 x 1,8	M 3	-	Nr. 5-40	-	Nr. 5-44	-	1/8" -40	-	-	-	Nr.5	-
2,5 x 2,0	M 3,5	M 2	Nr. 6-32	Nr. 1-64	Nr. 6-40	Nr. 0-80	-	-	-	-	-	Nr.11
	-	-	-	-	-	Nr. 1-72	-	-	-	-	-	Nr.10
2,8 x 2,24	-	M2,2	-	Nr. 2-56	-	Nr. 2-64	-	-	-	-	-	Nr.9
	-	M2,5	-	Nr. 3-48	-	Nr. 3-56	-	-	-	-	-	Nr.8
	-	-	-	-	-	-	-	-	-	-	-	Nr.7
3,15 x 2,5	M 4	M 3	-	Nr. 4-40	-	Nr. 4-48	-	-	-	-	-	Nr.6
	-	-	Nr. 8-32	Nr. 5-40	Nr. 8-36	Nr. 5-44	-	-	-	-	Nr.3	-
3,55 x 2,8	M 4,5	M3,5	Nr. 10-24	Nr. 6-32	Nr. 10-32	Nr. 6-40	3/16"-24	-	3/16"-32	-	Nr.2	Nr.4
4 x 3,15	M 5	M 4	Nr. 12-24	-	Nr. 12-28	-	-	-	7/32"-28	-	Nr.1	-
4,5 x 3,55	M 6	-	1/4" - 20	Nr. 8-32	1/4" -28	Nr. 3-36	1/4" - 20	-	1/4" - 26	-	Nr.0	Nr.3
5 x 4	-	M 5	-	Nr. 10-24	-	Nr.10-32	-	3/16"-24	-	3/16"-32	-	Nr.2
5,6 x 4,5	-	-	-	Nr. 12-24	-	Nr.12-28	-	-	9/32"-36	7/32"-28	-	Nr.1
6,3 x 5	M 8	M 6	5/16"-18	1/4" -20	5/16" 24	1/4" -28	5/16"-18	1/4"-20	5/16"-22	1/4"-26	-	Nr.0
7,1 x 5,6	-	-	3/8" - 16	-	3/8" -24	-	3/8" -16	-	3/8" - 20	9/32"-36	-	-
8 x 6,3	M 10	M 8	7/16"-14	5/16"-18	7/16"- 20	-	7/16"-14	5/16"18	7/16"-18	5/16-22	-	-
9 x 7,1	M 12	-	1/2" - 13	-	1/2" -20	-	1/2" -12	-	1/2" - 12	-	-	-
10 x 8	-	M 10	-	3/8" -16	-	3/8" -24	-	3/8"- 16	-	3/8"-20	-	-
11,2 x 9	M 14	-	9/16"-12	-	9/16"- 18	-	9/16"-12	-	9/16" -16	-	-	-
12,5 x 10	M 16	-	5/8" - 11	-	5/8" -18	-	5/8"- 11	-	3/8" - 14	-	-	-
14 x 11,2	M 18	-	3/4" - 10	-	3/4" -16	-	11/16"-11	-	11/16"-14	-	-	-
	M 20	-	-	-	-	-	3/4" -10	-	3/4" - 12	-	-	-
16 x 12,5	M 22	-	7/8" - 9	-	7/8" -14	-	7/8" - 9	-	7/8" - 11	-	-	-
18 x 14	M 24	-	1" - 8	-	1" - 12	-	1" - 8	-	1" - 10	-	-	-
20 x 16	M 27	-	1.1/8" - 7	-	1.1/8"-12	-	1.1/8" - 7	-	1.1/8" -9	-	-	-
	M 30	-	-	-	-	-	-	-	-	-	-	-
22,4 x 18	M 33	-	1.1/4" - 7	-	1.1/4"-12	-	1.1/4" -7	-	1.1/4" -9	-	-	-
25 x 20	M 36	-	1.3/8" - 6	-	1.3/8"-12	-	-	-	1.3/8" -8	-	-	-
28 x 22,4	M 39	-	1.1/2" - 6	-	1.1/2"-12	-	1.1/2"-6	-	1.1/2" -8	-	-	-
	M 42	-	-	-	-	-	-	-	1.5/8" -8	-	-	-
31,5 x 25	M 45	-	1.3/4" - 5	-	-	-	1.3/4"-5	-	1.3/4" -7	-	-	-
	M 48	-	-	-	-	-	-	-	-	-	-	-
35,5 x 28	M 52	-	2" - 4.1/2	-	-	-	2"-4.1/2	-	2" - 7	-	-	-
	M 56	-	-	-	-	-	-	-	-	-	-	-
40 x 31,5	M 60	-	2.1/4"- 4.1/2	-	-	-	2.1/4"-4	-	2.1/4" -6	-	-	-
	M 64	-	2.1/2" - 4	-	-	-	2.1/2"-4	-	2.1/2" -6	-	-	-
45 x 35,5	M 68	-	2.3/4" - 4	-	-	-	2.3/4"- 3.1/2	-	2.3/4" -6	-	-	-
50 x 40	-	-	3" - 4	-	-	-	3"-3.1/2	-	3" - 5	-	-	-
	-	-	3.1/4" - 4	-	-	-	3.1/4"- 3.1/4	-	3.1/4" - 5	-	-	-
	-	-	3.1/2" - 4	-	-	-	3.1/4"- 3.1/4	-	3.1/2" - 4	-	-	-
56 x 45	-	-	3.3/4" - 4	-	-	-	3.3/4"-3	-	3.3/4" - 4.1/2	-	-	-
	-	-	4" - 4	-	-	-	4" - 3	-	4" -4.1/2	-	-	-